

**SCM410/SCM410E
FOUR CHANNEL AUTOMATIC MICROPHONE MIXER**

**SCM410/SCM410E
MÉLANGEUR AUTOMATIQUE À QUATRE CANAUX**

**SCM410/SCM410E
AUTOMATISCHER 4-KANAL-MIKROFON-MISCHER**

**SCM410/SCM410E
CONSOLA MEZCLADORA AUTOMATICA DE MICROFONOS DE CUATRO CANALES**

**SCM410/SCM410E
MIXER AUTOMATICO A QUATTRO CANALI PER MICROFONI**



TABLE OF CONTENTS

DESCRIPTION	3
FEATURES	3
OPERATING PRINCIPLES	3
FRONT PANEL	3
REAR PANEL	4
DIP SWITCH FUNCTIONS	4
INSTALLATION	5
SUPPLIED HARDWARE	5
RACK MOUNTING	5
TABLE-TOP MOUNTING	6
FIXED MOUNTING	6
SCM410 CONNECTIONS	7
LINKING MULTIPLE MIXERS	7
BASIC MIXER OPERATION	8
LIMITER	8
EQUALIZER FUNCTIONS	8
SPECIFICATIONS	9
ADVANCED FUNCTIONS	10
LOGIC CONNECTION SPECIFICATIONS	10
SUGGESTED LOGIC APPLICATIONS	11
INTERNAL MODIFICATIONS	14



This symbol indicates that dangerous voltage constituting a risk of electric shock is present within this unit.



This symbol indicates that there are important operating and maintenance instructions in the literature accompanying this unit.

WARNING: Voltages in this equipment are hazardous to life. No user-serviceable parts inside. Refer all servicing to qualified service personnel. The safety certifications do not apply when the operating voltage is changed from the factory setting.

! IMPORTANT SAFETY INSTRUCTIONS !

- | | |
|--|---|
| <ol style="list-style-type: none"> 1. READ these instructions. 2. KEEP these instructions. 3. HEED all warnings. 4. FOLLOW all instructions. 5. DO NOT use this apparatus near water. 6. CLEAN ONLY with dry cloth. 7. DO NOT block any ventilation openings. Install in accordance with the manufacturer's instructions. 8. DO NOT install near any heat sources such as radiators, heat registers, stoves, or other apparatus (including amplifiers) that produce heat. 9. DO NOT defeat the safety purpose of the polarized or grounding-type plug. A polarized plug has two blades with one wider than the other. A grounding type plug has two blades and a third grounding prong. The wider blade or the third prong are provided for your safety. If the provided plug does not fit into your outlet, consult an electrician for replacement of the obsolete outlet. 10. PROTECT the power cord from being walked on or pinched, particularly at plugs, convenience receptacles, and the point where they exit from the apparatus. 11. ONLY USE attachments/accessories specified by the manufacturer. | <ol style="list-style-type: none"> 12.  USE only with a cart, stand, tripod, bracket, or table specified by the manufacturer, or sold with the apparatus. When a cart is used, use caution when moving the cart/apparatus combination to avoid injury from tip-over. 13. UNPLUG this apparatus during lightning storms or when unused for long periods of time. 14. REFER all servicing to qualified service personnel. Servicing is required when the apparatus has been damaged in any way, such as power-supply cord or plug is damaged, liquid has been spilled or objects have fallen into the apparatus, the apparatus has been exposed to rain or moisture, does not operate normally, or has been dropped. 15. DO NOT expose the apparatus to dripping and splashing. DO NOT put objects filled with liquids, such as vases, on the apparatus. 16. The MAINS plug or an appliance coupler shall remain readily operable. 17. The airborne noise of the apparatus does not exceed 70dB (A). 18. Apparatus with CLASS I construction shall be connected to a MAINS socket outlet with a protective earthing connection. 19. To reduce the risk of fire or electric shock, do not expose this apparatus to rain or moisture. 20. Do not attempt to modify this product. Doing so could result in personal injury and/or product failure. |
|--|---|

WARNING: This product contains a chemical known to the State of California to cause cancer and birth defects or other reproductive harm.

DESCRIPTION

The Shure Model SCM410/E is a four-channel automatic microphone mixer for use in sound reinforcement, audio recording, and broadcast applications. The SCM410 dramatically improves audio quality in any application where multiple microphones are required. Any low-impedance dynamic or condenser microphone (including wireless) can be used with the SCM410. Multiple SCM410 mixers can be linked to other SCM410 mixers, as well as to Shure Models FP410, SCM810, and SCM800.

Each input channel has a two-band equalizer and three logic terminals. The equalizer reduces unwanted low-frequency audio pickup and makes different microphone types—lavaliers, boundary and handheld—sound similar. The logic terminals can be used to control external devices.

The SCM410 operates on 100-120 Vac power and the SCM410E operates on 220-240 Vac power. Each mixer is supplied with a power cord, rack-mounting hardware, and a link cable.

FEATURES

- Fast, noise-free microphone selection, which automatically adjusts to changes in background noise
- Automatic gain adjustment as additional microphones are activated—NOMA (Number of Open Microphones Attenuated)
- Last Mic Lock-On circuit maintains ambient sound
- Fits in half-rack space
- Adjustable EQ for each channel
- Active balanced microphone-level XLR inputs and an active balanced Mic/Line level XLR output
- Unbalanced auxiliary-level phono output
- Bi-color channel activation and clipping LEDs
- Peak-responding output limiter with LED indicator
- Peak-responding output level meter

OPERATING PRINCIPLES

The operating concept behind the SCM410 Automatic Mixer is Shure's patented* *IntelliMix*® circuitry. *IntelliMix* delivers seamless automatic mixing by combining three separate functions:

- **Noise Adaptive Threshold.** Distinguishes between constant background noise (such as air conditioning) and changing sound (such as speech) for each input channel. It continuously adjusts the activation threshold so that only speech levels louder than the background noise activate a channel.

- **MaxBus.** Controls the number of channels that may be activated for a single sound source. One talker activates only one channel, even if multiple microphones "hear" that talker.
- **Last Mic Lock-On.** Keeps the most recently activated microphone open until another microphone is activated. Without Last Mic Lock-On, a long pause in conversation would cause all microphones to turn off, which would sound as if the audio signal had been lost. Last Mic Lock-On ensures that background ambience is always present.

*U.S. Patents 4,658,425 and 5,297,210. *IntelliMix* is a registered trademark of Shure Incorporated.

FRONT PANEL

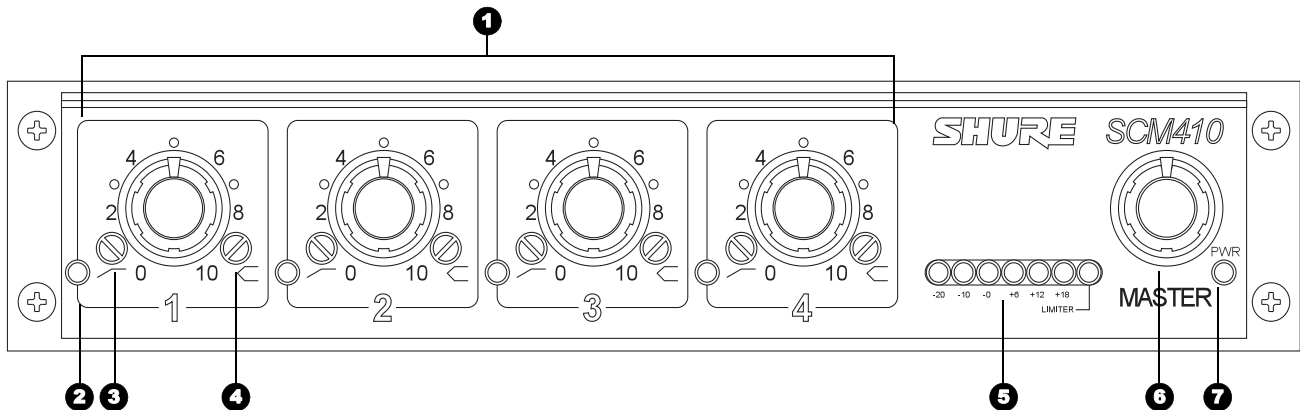

- 1 **Microphone Channel Gain Controls 1 - 4:** Allows adjustment of microphone gain.
- 2 **Input LED 1 - 4:** Lights green when channel is active; lights red at 6 dB below clipping level.
- 3 **Low-Cut Filter 1 - 4:** Provides adjustable low-frequency rolloff (high pass), reducing presence of undesirable low-frequency signals.
- 4 **High-Frequency Shelving Filter 1 - 4:** Provides level boost or cut in mid/high-frequency region for reduced sibilance from vocal microphones, or to compensate for off-axis coloration in lavalier microphones.

- 5 **Output Level Meter:** Six-segment LED meter indicates peak output signal level in dBu (0 dBu = 0.775V). The red LED illuminates when the output is 6 dB below clipping. The last LED indicates limiter action.
- 6 **MASTER Level Control:** Controls overall output level.
- 7 **POWER LED:** Lights green when mixer is plugged into a power source.

REAR PANEL

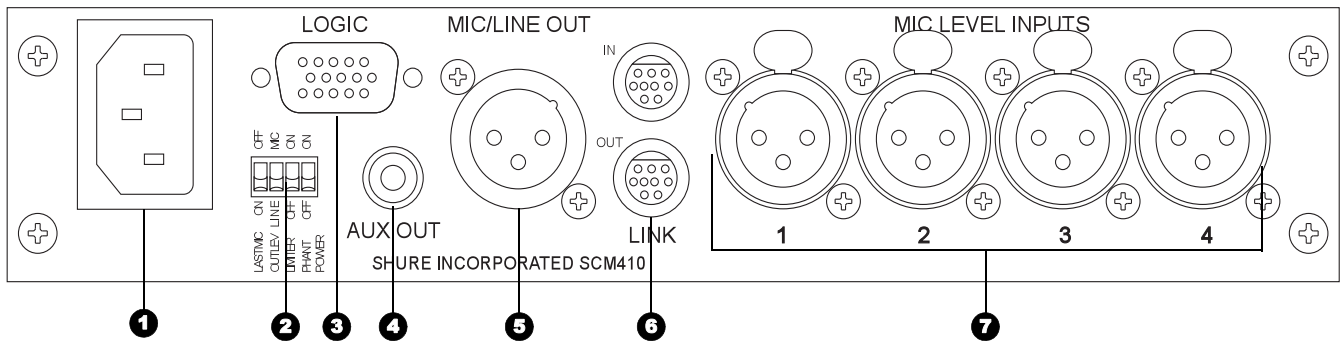

- ❶ **Power Connector:** Unit is energized when the power cord is plugged into a 100-120 Vac (SCM410) or 220-240 Vac (SCM410E) power source. **NOTE:** There is no power On/Off switch on this mixer.
- ❷ **DIP Switch:** The 4-position DIP switch provides additional functions. Refer to the “DIP Switch Functions” section.
- ❸ **Microphone Logic Connector:** High density DB-15 male connector provides connection to GATE OUT, MUTE IN, and OVERRIDE IN logic terminals on each channel. Refer to the “Advanced Functions” section. **NOTE:** THIS IS NOT A VGA MONITOR PORT.
- ❹ **AUX OUT Phono Connector:** Feeds consumer-level audio equipment, such as a tape recorder, VCR, or video camera. Not affected by MIC/LINE switch.
- ❺ **MIC/LINE XLR OUTPUT Connector:** Can be set for microphone or line-level output via a DIP switch.
- ❻ **LINK IN/OUT Connector:** Permits multiple SCM410/E, FP410, SCM810, SCM800, or AMS8100 mixers to be linked, creating additional inputs.
- ❼ **MIC LEVEL XLR INPUT Connectors:** Active balanced microphone-level XLR inputs. For instructions on how to modify the level of these inputs, refer to the “Internal Modifications” section.

DIP SWITCH FUNCTIONS

The rear panel DIP switches, shown in Figure 1, provide the functions listed in the table below.

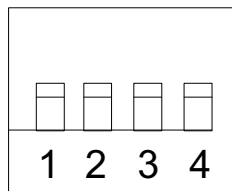

DIP SWITCHES
FIGURE 1

	Last Mic Lock-On	XLR Output Level	Limiter	12V Phantom Power
Switch Number	1	2	3	4
Switch Up	All mics off after hold time	Mic Level	ON	ON
Switch Down	ON*	Line Level*	OFF*	OFF*

*Factory setting.

Last Mic Lock-On: Keeps the most recently activated microphone turned on until another microphone is activated. When defeated, microphones turn off after their default hold time.

XLR Output Level: Sets the level of the XLR output to line or microphone level. Make sure the output level matches the input level of the device connected to the SCM410.

NOTE: The output level does not affect the auxiliary output (AUX OUT) level.

Limiter: Activates the output limiter and sets it to a default threshold of +16 dBu (see *Internal Modifications* for other threshold settings).

12V Phantom Power: When this switch is in the ON position, the SCM410 provides 12Vdc phantom power to each XLR microphone input. This function is particularly useful when using condenser microphones, since most condenser microphones require phantom power.

NOTE: Phantom power does not affect the operation of balanced dynamic microphones. They can be connected to the SCM410 in combination with condenser microphones that use phantom power. For instructions on how to disable phantom power by channel, refer to the “Internal Modifications” section.

INSTALLATION

SUPPLIED HARDWARE

- 4 rubber feet
- 1 rackmount bracket, long
- 1 rackmount bracket, short
- 2 straddle brackets
- 10 bracket screws, 6 mm (1/4 in.)
- 4 rackmount screws, 2.54 cm (1 in.)
- 4 plastic washers
- 4 wood screws, 1.25 cm (1/2 in.)

RACK MOUNTING

The SCM410 is supplied with hardware for mounting one or two units to a 19-inch audio equipment rack. The hardware can also be used to rack mount other Shure products, including the SCM268, SCM262, DFR11EQ, and the DP11EQ.

Single Mixer (Half Rack) Installation

1. Attach the short and long rackmount brackets to the SCM410/E with eight (8) of the supplied bracket screws.

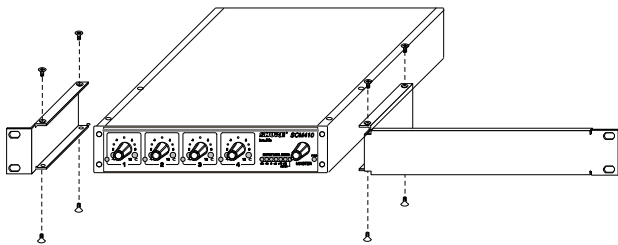

INSTALLING HALF-RACK MOUNTING BRACKETS

2. Place the mixer in an equipment rack and secure it with the supplied rackmount screws and plastic washers.

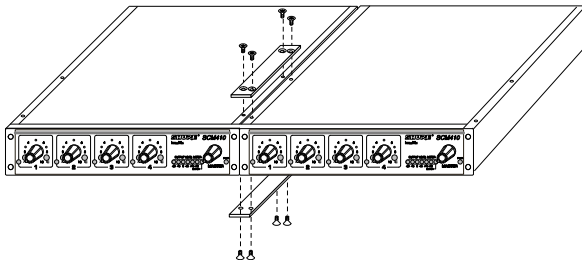

RACK MOUNTING A SINGLE SCM410/E MIXER

Dual Mixer (Full Rack) Installation

1. Place the two mixers side-by-side and connect them with two (2) straddle brackets. The brackets should straddle the recessed edges on the top and bottom of each mixer.

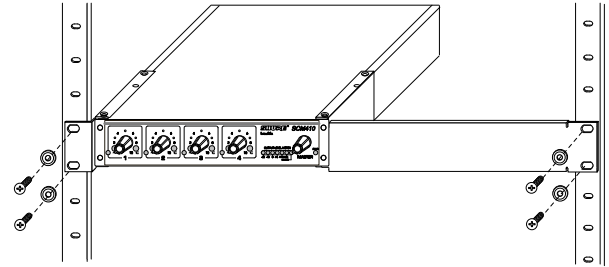

INSTALLING STRADDLE BRACKETS

2. Fasten the straddle brackets using eight (8) bracket screws.
3. Attach the *short* rackmount brackets to the outsides of the combined mixers with eight (8) of the bracket screws.

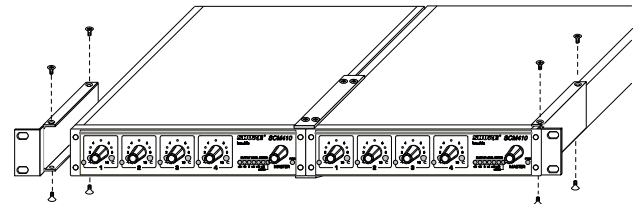

INSTALLING FULL-RACK MOUNTING BRACKETS

4. Place the mixer in an equipment rack, using the supplied rackmount screws and plastic washers.

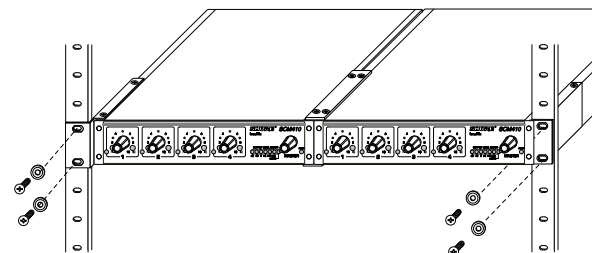

RACK MOUNTING DUAL SCM410/E MIXERS

TABLE-TOP MOUNTING

Adhere the four (4) supplied rubber feet to the bottom of the mixer at each corner. This will keep it from sliding and protect the table surface.

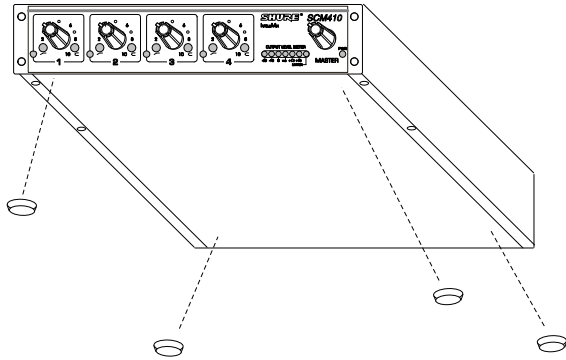

ATTACHING RUBBER FEET FOR TABLE-TOP MOUNTING

FIXED MOUNTING

TOP MOUNT

1. Fasten the straddle brackets to the recessed edges of the chassis, using four (4) bracket screws.

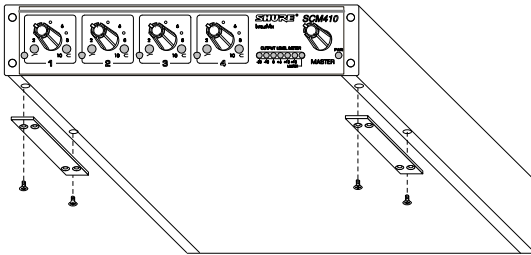

INSTALLING STRADDLE BRACKETS FOR TOP MOUNTING

2. Fasten the straddle brackets to the top of the mounting surface, using the four (4) supplied wood screws.

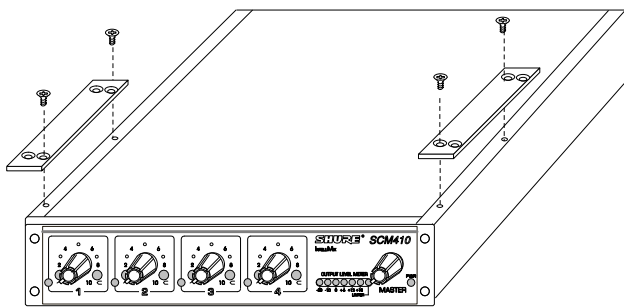

SECURING MIXER TO TOP MOUNTING SURFACE

HANGING MOUNT

1. Fasten the straddle brackets to the top of the mixer.

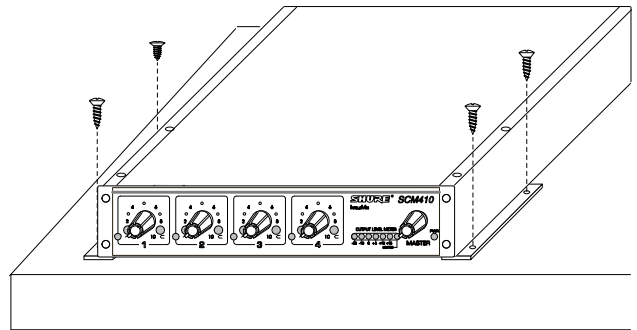

INSTALLING STRADDLE BRACKETS FOR HANG MOUNTING

2. Fasten the straddle brackets to the bottom of the mounting surface, using the four (4) supplied wood screws.

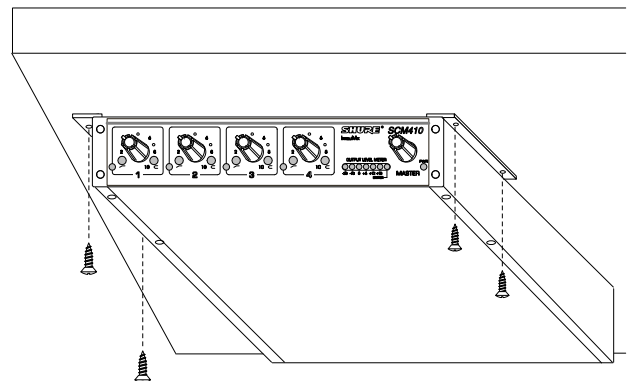

SECURING MIXER TO BOTTOM MOUNTING SURFACE

SCM410 CONNECTIONS

1. Connect microphone signal sources to the Channel Input connectors. Use conventional 2-conductor shielded audio cables.
2. If any condenser microphones are connected, set the +12V phantom power DIP switch to ON.
3. Connect the SCM410 Mic/Line Level Output to the input of mixers, EQs, amplifiers or recorders.
4. Connect the power cord to 100-120 Vac (SCM410) or 220-240 Vac (SCM410E)

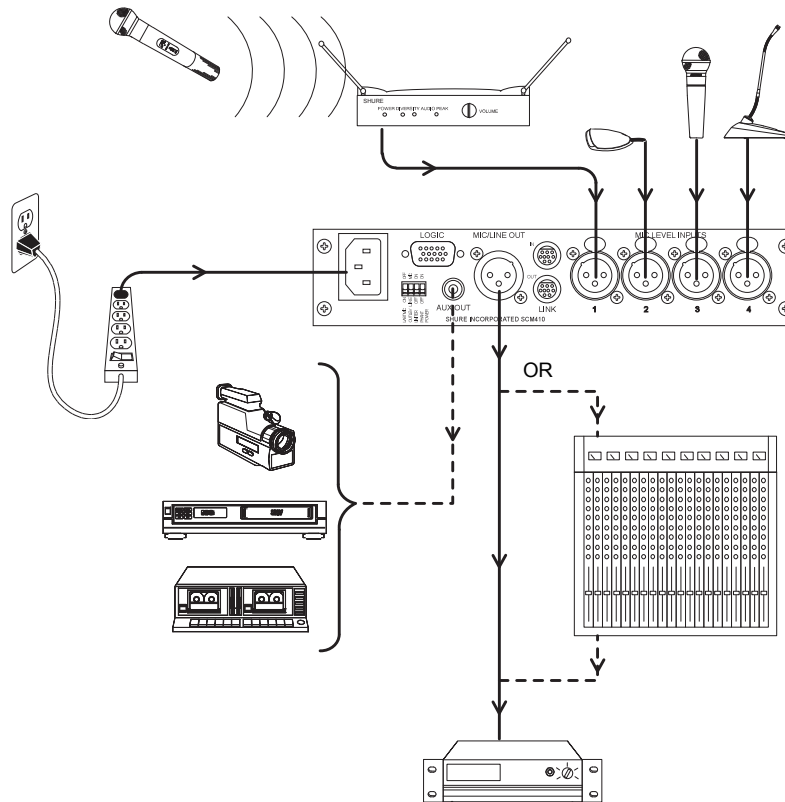

LINKING MULTIPLE MIXERS

If more than four inputs are needed, multiple Shure SCM410, FP410, or SCM810 mixers can be linked by connecting the LINK OUT of the first mixer to the LINK IN of the next mixer, and so on. See Figure 2. Leave the LINK IN jack of the *first* mixer and the LINK OUT jack of the *last* mixer unconnected.

When properly linked, the mixers will operate as a system. Automatic mixing functions will be shared by all units. All input signals appear at all linked mixer outputs. Each mixer's Master level control only controls its own output. However, actual off-attenuation will increase as more mixers are linked. This reduces excessive noise and reverberation contributed by the increased number of microphones.

When properly linked, the mixers will operate as a system. Automatic mixing functions will be shared by all units. All input signals appear at all linked mixer outputs. Each mixer's Master level control only controls its own output. However, actual off-attenuation will increase as more mixers are linked. This reduces excessive noise and reverberation contributed by the increased number of microphones.

IMPORTANT: When using logic terminals on linked mixers, connect the LOGIC GROUND terminals of each unit together.

NOTE: SCM410 link connections are unbalanced. To minimize hum and noise, avoid using longer link cables. Use high quality, shielded cable, and keep them away from sources of magnetic or electrical noise, such as power transformers or

light dimmers. To minimize ground currents, make sure linked mixers are connected to the same AC power mains.

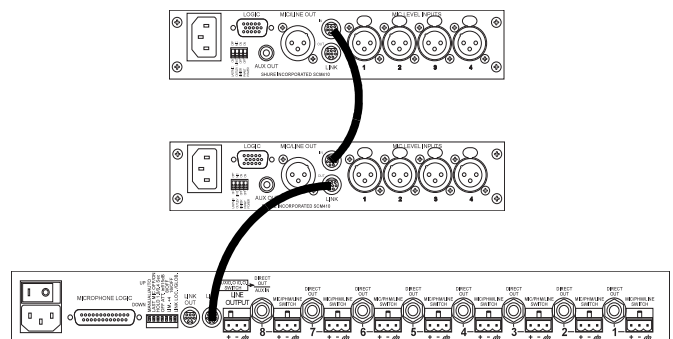

LINKED SCM410 AND SCM810 MIXERS
FIGURE 2

BASIC MIXER OPERATION

1. Adjust each channel level so that its Overload LED flickers only during very loud speech or noise.
2. Adjust the Low-Cut and High-Frequency controls adjacent to each Input Gain control so that the microphones sound similar.
3. Adjust the Master level control for the required output level, as indicated by the output peak meter. The SCM410 is now ready for use.

LIMITER

Output limiters prevent distortion during loud program peaks without affecting normal program levels. This keeps the devices connected to the SCM410 output from becoming overloaded. Increasing individual or Master controls on the SCM410 increases average output and, in turn, the amount of limiting.

The limiter may be turned on via the rear panel DIP switch. The default limiter threshold is +16 dBu. As supplied, the limiter is defeated.

NOTE: Limiter thresholds can be changed from their factory settings. Refer to the *INTERNAL MODIFICATIONS* section.

EQUALIZER FUNCTIONS

Low Cut Filter (High-Pass)

Low-cut filters are used to reduce unwanted low frequency sounds such as footsteps, motorized traffic, and to control proximity effect. The SCM410 has a one-pole, low-cut (high-pass) filter of 6 dB per octave. The low-cut filter allows all frequencies above its cutoff point to pass through unchanged. Frequencies below the cutoff are attenuated (see Figure 3). The cutoff point is defined as the frequency where the signal has dropped 3 dB relative to the flat, or bandpass, region. Below the cutoff point, the filter exhibits increasingly more attenuation as the frequency diminishes.

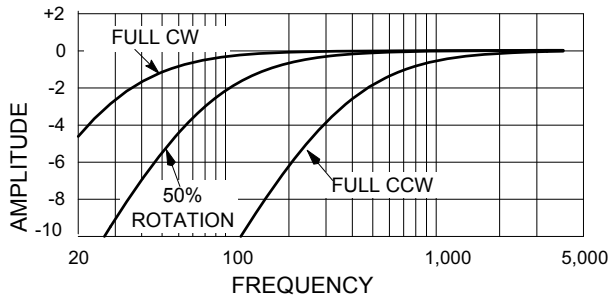

LOW-CUT FILTER EFFECTS
FIGURE 3

High-Frequency Shelving

The fixed-frequency equalizer produces a 6 dB boost or cut at 5 kHz and above (see Figure 4). High-frequency shelving is extremely useful for boosting flat frequency response and tempering sibilant vocal microphones or enhancing the sound of off-axis lavalier microphones.

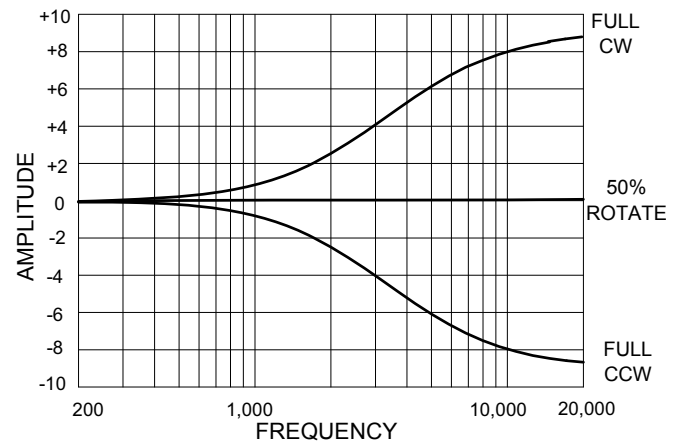

HIGH-FREQUENCY SHELVING EFFECTS
FIGURE 4

SPECIFICATIONS

Measurement Conditions (unless otherwise specified): Line voltage 120 Vac, 60 Hz (SCM410) or 230 Vac, 50 Hz (SCM410E); full gain; 1 kHz, one channel activated; source impedances: Mic 150 Ω; terminations: Line/Mic Aux 10 kΩ

Frequency Response (at 1 kHz, channel controls centered)

50 Hz to 20 kHz ±2 dB; -3 dB corner at 25 Hz

Voltage Gain (typical, controls full clockwise)

Input	Output		
	Line	Mic	Aux
Low-impedance mic (150 Ω)	80 dB	40 dB	68 dB

Inputs

Input	Impedance		Input Clipping Level
	Designed for use with	Actual (typical)	
Mic	19-600 Ω	1.4 kΩ	-14 dBV

Outputs

Output	Impedance		Output Clipping Level
	Designed for use with	Actual (typical)	
Line	≥5k Ω	300 Ω	+22 dBV
Mic	≥600 Ω	3 Ω	-20 dBV
Aux	≥10k Ω	1.5 k Ω	+12 dBV

Total Harmonic Distortion

<0.1% at +4 dBu output level, 50 Hz to 20 kHz (through 22 Hz to 22 kHz filter; Input at 12 o' clock and Master at 12 o' clock, all other controls full counterclockwise)

Hum and Noise (150 Ω source; through 22 Hz to 22 kHz filter)

Equivalent Input Hum and Noise: -123 dBV max., -125 dBV typical

Output Hum and Noise (channel controls full counterclockwise):

Master full counterclockwise: -90 dBV
Master full clockwise: -70 dBV

Common Mode Rejection

>70 dB at 1 kHz

Polarity

All inputs to all outputs are non-inverting

Input Channel Activation

Attack Time: 4 ms
Hold Time: 0.4 s
Decay Time: 0.5 s

Off-Attenuation

13 dB

Overload and Shorting Protection

Shorting outputs, even for prolonged periods, causes no damage. Microphone inputs are not damaged by signals up to +10 dBV (3V)

Equalization

Low-frequency: 6 dB/octave cut, adjustable corner from 25 to 320 Hz
High-frequency: ±6 dB at 5 kHz, ±8 dB at 10 kHz, shelving

Limiter

Type: Peak
Threshold: +16 dBu (at output)
Attack Time: 2 ms
Recovery Time: 300 ms
Indicator: Lights red when limiting occurs

Input LEDs

Green on channel activation, red at 6 dB below clipping

Phantom Power

12 Vdc open-circuit through 680 Ω resistors

Operating Voltage

SCM410: 100-120 Vac rated nominal, 50/60 Hz, 100 mA (maximum)

SCM410E: 220-240 Vac rated nominal, 50/60 Hz, 50 mA (maximum)

Mains Inrush Current (230 Vac, SCM410E only)

0.7 A peak

Temperature Range

Operating: -7° to 49° C (20° to 120° F)

Storage: -29° to 74° C (-20° to 165° F)

Overall Dimensions

44 mm H x 219 mm W x 267 mm D (1-3/4 x 8-5/8 x 10-1/2 in.)

Net Weight

1.75 kg (3.86 lbs)

Certifications

SCM410: UL LISTED to UL 6500 and cUL LISTED to E65 Canada.

SCM410E: Conforms to applicable European Union Directives. Low Voltage Directive, 2006/95/EC: Certified to EN 60065. Eligible to bear CE marking. Conforms to European EMC Directive 2004/108/EC. Meets Harmonized Standards EN55103-1:1996 and EN55103-2:1996 for residential (E1) and light industrial (E2) environments.

Authorized European Representative:

Shure Europe GmbH

Headquarters Europe, Middle East & Africa

Department: EMEA Approval

Wannenacker Str. 28

D-74078 Heilbronn, Germany

Phone: +49 7131 72 14 0

Fax: +49 7131 72 14 14

Email: EMEAsupport@shure.de

Replacement Parts

Knob, Master (white).....	95A8238
Knob, Channel Gain (blue)	95B8238
Line (Power) Cord (SCM410)	95B8389
Line (Power) Cord (SCM410E).....	95B8778
Link Cable	95B8889
Fuse, SCM410	
(5 x 20 mm, T 125mA L, 250V, time delay).....	80AA730
Fuse, SCM410E	
(5 x 20 mm, T 50mA L, 250V, time lag)	80J380
Long Rack Mount Bracket.....	53A8484
Short Rack Mount Bracket.....	53E8484
Straddle Bracket	53B8443
Bagged Hardware Kit.....	90AW8100

Optional Accessories

Line (Power) Cord, 230-240 Vac (UK)	95A8713
External 50 dB Line Pad	A15LA

Service Statement

For additional service or parts information, please contact the Shure Service Department at 1-800-516-2525. Outside the United States, please contact your authorized Shure Service Center.

ADVANCED FUNCTIONS

CAUTION: Use of Advanced Functions is recommended only for qualified audio technicians.

LOGIC CONNECTION SPECIFICATIONS

The SCM410 logic functions expand the range of installation and control options. Logic can be used for everything from simple cough switches to elaborate computer-controlled room systems. (Shure's *AMS Update* publication contains additional applications of advanced logic. This publication is available by contacting the Shure Applications Department.) The following logic functions are available for each channel:

GATE OUT: Follows channel gating and goes to logic "low" (sinks current) when microphone is gated on. 500 mA of current sinking ability is provided (see Figure 5A).

MUTE IN: Applying logic "low" (from GATE OUT or a switch closure to logic ground) gates channel off (see Figure 5B). Channel output drops to $-\infty$.

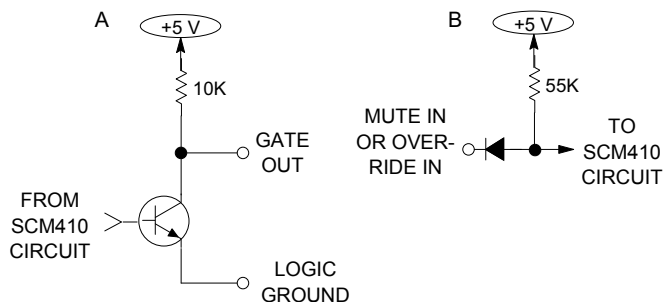

LOGIC EQUIVALENT CIRCUIT DIAGRAM
FIGURE 5

VERRIDE IN: Applying logic "low" (from GATE OUT or a switch closure to logic ground) forces channel on (see Figure 5B). When both Mute and Override are activated, Mute takes precedence (see *Internal Modifications* for Override precedence).

LOGIC GROUND: Logic ground is distinct from audio ground. Make all logic ground connections to this pin, including power supply ground of external logic circuitry. To avoid switching clicks, *do not* connect logic ground to audio, chassis or rack grounds.

Logic controls are accessed through the high density DB-15 multi-pin connector on the rear panel (Figure 6). Pin connections are shown in the following table.

LOGIC CONNECTIONS

Pin No.	Logic Function
1	VERRIDE IN 1
2	VERRIDE IN 2
3	VERRIDE IN 3
4	GATE OUT 4
5	LOGIC GROUND
6	GATE OUT 1
7	GATE OUT 2
8	GATE OUT 3
9	NO CONNECTION
10	MUTE IN 4
11	MUTE IN 1
12	MUTE IN 2
13	MUTE IN 3
14	VERRIDE IN 4
15	NO CONNECTION

Logic Function	Pin No.
GATE OUT 1	6
GATE OUT 2	7
GATE OUT 3	8
GATE OUT 4	4
VERRIDE IN 1	1
VERRIDE IN 2	2
VERRIDE IN 3	3
VERRIDE IN 4	14
MUTE IN 1	11
MUTE IN 2	12
MUTE IN 3	13
MUTE IN 4	10
LOGIC GROUND	5
NO CONNECTION	15
NO CONNECTION	9

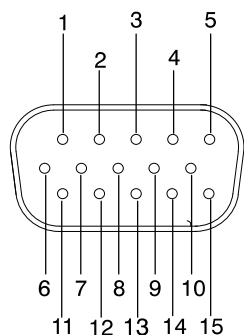

LOGIC CONNECTOR
FIGURE 6

SUGGESTED LOGIC APPLICATIONS

This section contains suggestions on the uses of the SCM410's logic capabilities. Note that uses of these functions are not limited to the listed applications. The user is limited only by imagination and creativity. For additional suggestions and solutions to installation problems, contact the Shure Applications Department.

COUGH BUTTON

The talker can turn off his or her microphone during coughing or private conversations by installing an SPST pushbutton switch between the MUTE IN and Logic Ground pins for each channel to be modified (see Figure 7). When a channel is muted, no audio is passed. (See *Dead Zone on MUTE IN Defeat* paragraph in the *Internal Modifications* section for more information on MUTE IN logic.)

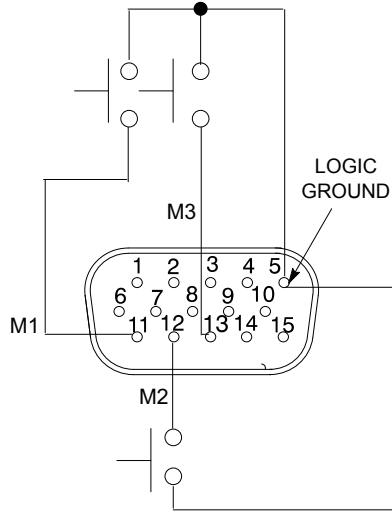

COUGH BUTTONS
FIGURE 7

CHAIRPERSON-CONTROLLED MUTING

The chairperson can, by activating a switch, silence all other microphones and be heard without interruption. For operation in this mode, connect all the MUTE IN pins together *except that of the chairperson's channel*, and wire an SPST pushbutton or toggle switch between those MUTE IN and Logic Ground pins (see Figure 8).

An alternative to a switch is to connect the chairperson's GATE OUT to the MUTE IN of other channels. When the chairperson's microphone activates, all other microphones mute.

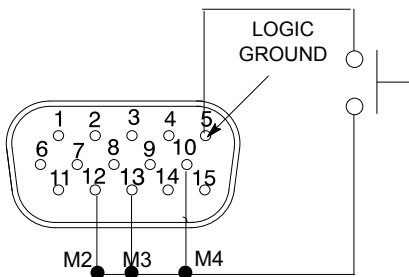

CHAIRPERSON-CONTROLLED MUTING
FIGURE 8

REMOTE CHANNEL-ON INDICATORS

Remote indicators can be used to indicate when a talker's microphone is on. Connect the LEDs and a 5-volt supply to the GATE OUT pins (See Figure 9). To avoid switching clicks in the audio output, *do not* ground the power supply negative terminal in the audio system or rack ground.

IMPORTANT: If a single cable is used for the microphone audio signal *and* the LED dc power, separate shielded pairs **must** be used. Failure to carry the dc power on a shielded pair may result in audible clicking due to capacitive coupling between the dc power lines and microphone lines.

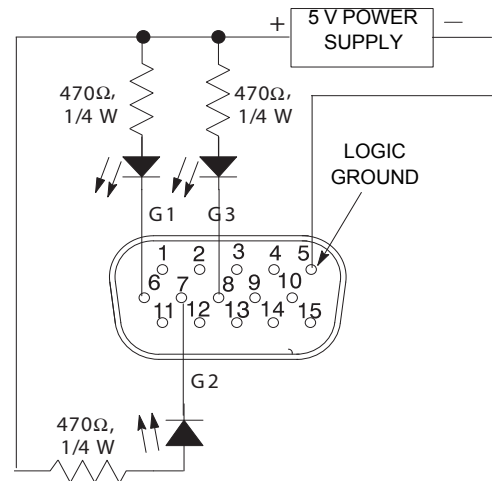

REMOTE CHANNEL-ON INDICATORS
FIGURE 9

DISABLING THE GATING FUNCTION (BYPASS)

To keep certain microphones on at all times, wire the desired microphone channel's OVERRIDE IN pins together to the Logic Ground pin. The selected channels now function as they would in a non-automatic mixer (see Figure 10). To perform this modification internally on the mixer, refer to the *Shorting Override In to Logic Ground Internally* paragraph in the *Internal Modifications* section.

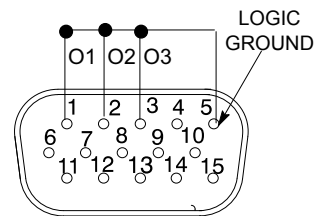

GATING BYPASS
FIGURE 10

INHIBITING GATING FOR UNWANTED SOUNDS

MaxBus attempts to activate only one microphone per sound source. Muting a microphone channel prevents its audio from appearing at the mixer's output. However, the muted microphone still communicates with other mic channels via MaxBus. *A sound source picked up by a muted microphone will not activate other microphones.*

Sound sources that may cause unwanted microphone channel activation include:

- Heating, ventilation, or air conditioning systems
- A noisy fax machine or printer
- A squeaky door
- A paging system loudspeaker
- An audio teleconferencing return signal loudspeaker

The SCM410 can prevent these and similar sounds from activating microphones as follows:

1. Place one microphone near the unwanted sound source. Connect that microphone's signal to a channel input, *-or-* connect the unwanted sound source directly into a channel input.
2. Mute that channel using the logic terminal (see Figure 11). To perform this modification internally on the mixer, refer to the *Shorting Mute In to Logic Ground Internally* paragraph in the *Internal Modifications* section.
3. Adjust the channel gain control just past the level where unwanted sounds do not activate other microphones in the system. If the channel gain is set too high, the other microphones may not be activated by the *desired* sounds. If set too low, unwanted sounds will continue to activate other microphones.

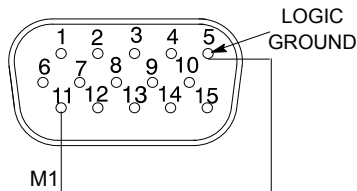

INHIBITING GATING FOR UNWANTED SOUNDS
FIGURE 11

LOUDSPEAKER MUTING

Some applications require a loudspeaker to be placed near each talker to provide audio reinforcement, or to permit telephone conversation or conference monitoring. Each loudspeaker can cause feedback unless it is automatically switched off when the talker near it speaks. To provide this function, connect the GATE OUT terminal of each channel to a separate loudspeaker muting relay (See Figure 12). Recommended relays are Radio Shack 275-248, Omron G2R-14-DC12 (Digi-Key number Z745-ND), Potter & Brumfield R10-E1Y2-V185 (Newark number 45F106), or equivalent.

NOTE: A diode across each relay coil is required to suppress inductive voltage spikes which may damage the SCM410.

An existing sound system using 24-volt relays can be used with the SCM410 without modification if the relay coil current draw is under 500 mA.

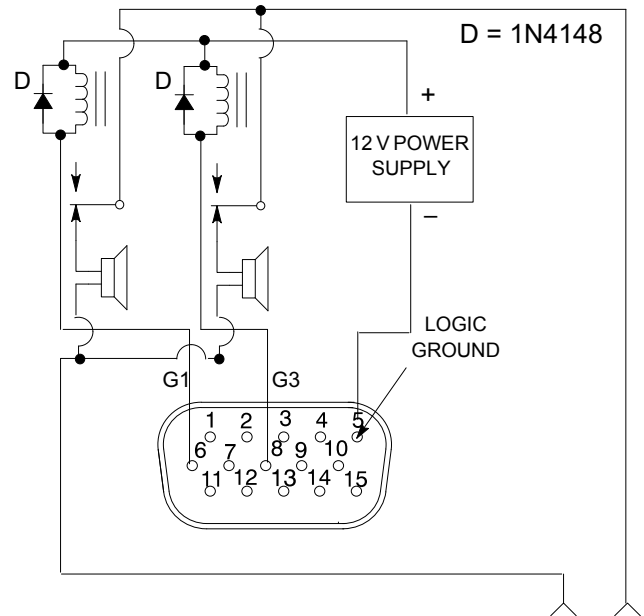

LOUDSPEAKER MUTING
FIGURE 12

"FILIBUSTER" MODE

Normally, when several people talk, each microphone gates on so that no speech is missed. In "filibuster" mode, a microphone remains gated on until the talker pauses long enough for that microphone to gate off. No other microphone can gate on until that microphone gates off. This prevents talkers from being interrupted.

To establish filibuster mode, refer to Figure 13 and proceed as follows:

1. Perform the *Mute to Inhibit* modification as presented in the *Internal Modifications* section.
2. Connect all the MUTE IN pins together on the modified channels.
3. Connect all the GATE OUT pins together on the modified channels.
4. Connect the GATE OUT pin of one modified channel to the MUTE IN pin of another modified channel.
5. Turn the Last Mic Lock-On switch to OFF.

NOTE: To prevent high-frequency oscillation, do not wire a GATE OUT pin to a MUTE IN pin on the same channel unless the *Mute to Inhibit* modification has been made.

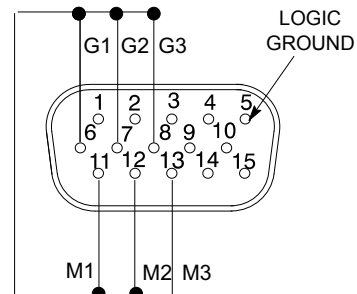

"FILIBUSTER" MODE
FIGURE 13

INHIBIT FUNCTION

For information on the inhibit function, refer to the *Internal Modifications* section.

REMOTE VOLUME CONTROL

The level of the Aux or Master output can be controlled from an external VCA (Voltage Controlled Amplifier) such as the RU-VCA1 from Radio Design Labs (Tel. 1-800-281-2683, or www.rdl.net.com). To connect a VCA to the SCM410, proceed as follows:

1. Connect the SCM410 Line output to the VCA line input.
2. Connect the VCA line output to the external device.
3. For remote Master level control, set the SCM410 Master control to 5.

DIODE ISOLATION OF LOGIC CONTROLS

Two or more control functions that use the same logic pins can be isolated with diodes, as shown in Figure 14. With this modification, a channel can be muted by an overall group mute switch, or by its own cough button.

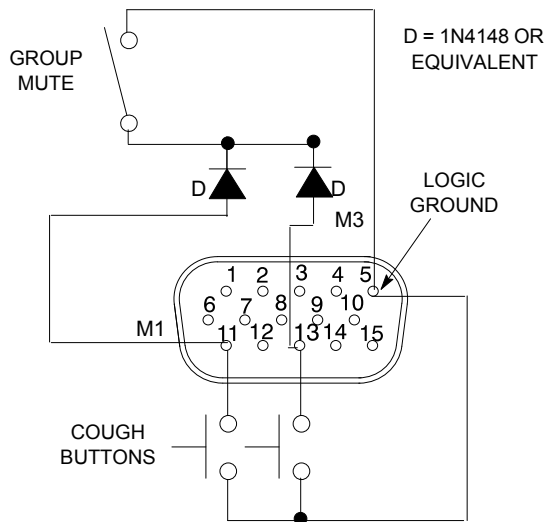

DIODE ISOLATION OF LOGIC TERMINALS
FIGURE 14

DIGITAL CONTROLS OR MICROCOMPUTERS

The SCM410 logic pins can interface with custom-designed digital control circuitry or microcomputers for unlimited possibilities of system control functions.

EXTERNAL LOGIC DEVICES

SCM410 logic levels are directly compatible with TTL and 5V CMOS logic families. Mixer logic may be used with 15V CMOS logic if a pull-up resistor is used with each GATE output. See Figure 15.

NOTE: For information on logic gate use, refer to the *TTL Cookbook* and *CMOS Cookbook*, both by D. Lancaster, Howard Sams Publishing Co.

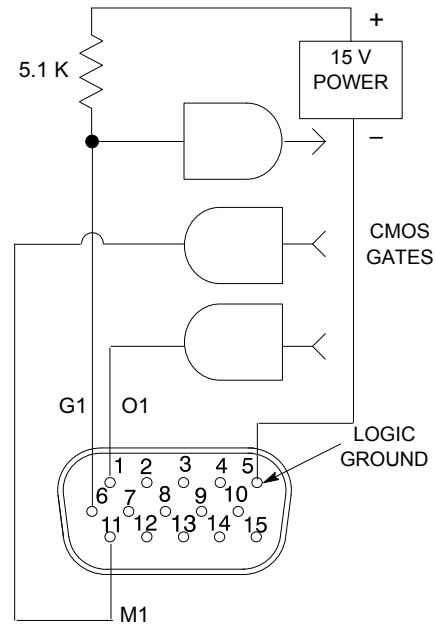

15V CMOS
FIGURE 15

INTERNAL MODIFICATIONS

- Only make changes to jumpers (X) and resistors (R). The circuit board contains holes where resistors are to be added.
- For Channel modifications, the first character of the reference designator indicates the channel number, (i.e., R1027 refers to a Channel 1 resistor, X2001 refers to a Channel 2 jumper, etc.). Modifications affecting the Master section are preceded by a "9" (i.e., X9001).

- All Channel modifications in this section use Channel 1 as an example.

NOTE: Remove AC power before opening the unit.

DISASSEMBLING THE SCM410/SCM410E

To access the printed circuit board for internal modifications, proceed as follows:

1. Remove the power cord from the ac power source.
2. Remove the knobs, retainer nuts, and washers from the front panel, as shown in Figure 16

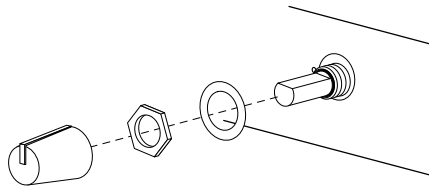

KNOB ASSEMBLY AND DISASSEMBLY
FIGURE 16

3. Remove the four screws at each corner of the rear panel.
4. Remove the two screws at each bottom corner of the front panel.
5. Slide the back panel and printed circuit board out from the rear of the chassis.

CAUTION: When reassembling the SCM410, DO NOT OVERTIGHTEN the knob retainer nuts. Damage to the internal components will result if too much force is used.

INSERTING A 12 DB MIC PREAMPLIFIER PAD

A microphone preamplifier channel gain can be reduced by 12 dB. This may be desirable with high-output microphones.

Procedure:

1. Short jumper X1000.
2. Remove resistor R1006.

DISABLING PHANTOM POWER BY CHANNEL

To disable phantom power for a given microphone input channel, remove the resistor specified in the following table.

Channel	Remove Resistor
1	R1005
2	R2005
3	R3005
4	R4005

INSERTING AN INPUT LINE PAD

To insert a 40 dB line pad for a given microphone input, remove the resistors specified in the following table.

Channel	Remove Resistor
1	R1005, R1006
2	R2005, R2006
3	R3005, R3006
4	R4005, R4006

DISABLING THE MASTER LEVEL CONTROL

The Master gain control can be disabled to prevent tampering. Refer to the following table for gain levels and resistor values.

Master Section Gain	Resistance
-6 dB	5.1 kΩ
0	10 kΩ
6 dB	20 kΩ

Procedure:

1. Remove resistor R9203.
2. Install new resistor at jumper R9173.

CHANGING THE LIMITER THRESHOLD

To change the limiter threshold from the preset value of +16 dBu, modify the circuitry according to the following table.

CHANGE LIMITER THRESHOLD				
Limiter Threshold (dBu)	Limiter DIP switch	X9003	R9149	R9142
0	On	--	Remove	20k
+4	On	Short	--	--
+8	Off	Short	--	--
+12	On	--	Remove	110k
+16 (default)	On	--	--	--
+20	On	--	Remove	300k
+24	On	--	Remove	400k

CHANGING HOLD TIME

To change the hold time from the preset value of 0.4 seconds, modify the circuitry according to the following table.

CHANGE HOLD TIME			
Hold Time (seconds)	X9000	R9073	R9079
0.3	--	--	2M
0.4 (default)	--	--	--
1.0	Short	--	--
1.5	Short	470k	--

LOCAL AUX OPERATION

This modification removes the auxiliary audio from the SCM410 outputs. Auxiliary audio originates from the aux inputs of the Shure SCM810, SCM800, and AMS8100 mixers when linked to the SCM410.

Procedure:

1. Remove resistor R9187.

MUTE IN PRECEDENCE TO OVERRIDE IN PRECEDENCE

When both MUTE IN and OVERRIDE IN logic are grounded, the Override mode will take precedence (as supplied, the MUTE IN takes precedence over OVERRIDE IN).

Procedure:

1. Short jumper X1005.
2. Remove resistor R1087.

DEAD ZONE ON MUTE IN DEFEAT

As supplied, MUTE IN is intended for use as a momentary cough button or privacy function (mute when necessary). However, if the MUTE IN is intended to be used so that the talker must unmute microphones to enable speech pickup (unmute when needed), this modification is needed. This removes the muted channel from the MaxBus which eliminates "dead zones." A dead zone is an area in which a microphone picks up a talker through a muted microphone and other microphones do not activate for that talker.

Procedure:

1. Short jumper X1002.

CHANGING MUTE IN TO INHIBIT

As supplied, a channel will mute when its MUTE IN terminal is grounded. The mute function for each channel can be modified so that a logic "low" at the MUTE IN terminal prevents that channel from gating on if it is off, but allows it to remain on if it is already on. Use this modification to enable Filibuster Mode.

Procedure:

1. Short jumper X1007.

IMPORTANT: To prevent high-frequency oscillation, never connect the GATE OUT to the MUTE IN of the same channel unless the "Inhibit" modification has been made.

CHANGING OVERRIDE IN TO MUTE IN (FILIBUSTER MODE)

This modification should only be performed with the *Change MUTE IN to Inhibit* modification described above. This is only necessary if the Mute function is desired along with Filibuster Mode.

CHANGING THE OFF-ATTENUATION LEVEL

This procedure changes the off-attenuation level from -13 dB (as supplied). Refer to the following table for attenuation levels and resistor values.

Off-Attenuation Level	Resistor Value
10 dB	18 k Ω
13 dB (default)	30 k Ω
20 dB	75 k Ω
30 dB	250 k Ω
∞ dB	open circuit

NOTE: As more Input channels are added to the system, the off-attenuation increases slightly.

GROUP GATING

With this modification, several channels can be grouped together so that all of them activate whenever one of them activates. This is useful for miking choirs.

SHORTING OVERRIDE IN TO LOGIC GROUND INTERNALLY

This modification is equivalent to shorting one of the channel *OVER-RIDE IN* to the *LOGIC GROUND* pin via the high density DB-15 logic connector. With this modification, a channel is always on.

SHORTING MUTE IN TO LOGIC GROUND INTERNALLY

This modification is equivalent to shorting a channel *MUTE IN* to the *LOGIC GROUND* pin via the high density DB-15 logic connector. With this modification, a channel is always muted.

DISABLING AUTOMATIC MIXING FUNCTION BY CHANNEL

This modification removes a given channel from the *IntelliMix* automatic mixing circuitry, so that a source such as music can be played through a channel of the SCM410 without affecting the automatic mixing of the unmodified channels.

MANUAL MODE ENABLE

This modification defeats the automatic mixing functionality of the SCM410, so that it operates as a standard 4 x 1 mixer.

Procedure:

1. Short jumper X1006.
2. Remove resistors R1087 and R1082.

Procedure:

1. Remove resistor R9178.
2. Install new resistor at jumper points R9177.

Procedure:

1. Locate pad PD1000.
2. Solder a wire from PD1000 to the other channels in the group. For example, to gate channels 1-3 as a group, solder a wire connecting PD1000, PD2000, and PD3000.

Procedure:

1. Short jumper X1003.

Procedure:

1. Short jumper X1004.

Procedure:

1. If necessary, modify the channel input to accept line level signals. Refer to the *Inserting an Input Line Pad* paragraph.
2. Modify the channel's *Override In to On*. Refer to the *Shorting Override In to Logic Ground Internally* paragraph.
3. Short jumper X1001 to remove the channel from the MaxBus.
4. Remove R1064 to remove the channel from the Last Mic Lock-On Bus.

Procedure:

1. Short jumper X9001.



United States:
Shure Incorporated
5800 West Touhy Avenue
Niles, IL 60714-4608 USA

Phone: 847-600-2000
Fax: 847-600-1212
Email: info@shure.com

Europe, Middle East, Africa:
Shure Europe GmbH
Wannenäckestr. 28,
74078 Heilbronn, Germany

Phone: 49-7131-72140
Fax: 49-7131-721414
Email: info@shure.de

Asia, Pacific:
Shure Asia Limited
Unit 301, 3rd Floor
Citicorp Centre
18, Whitfield Road
Causeway Bay, Hong Kong

Phone: 852-2893-4290
Fax: 852-2893-4055
Email: info@shure.com.hk

**Canada, Latin America,
Caribbean:**
Shure Incorporated
5800 West Touhy Avenue
Niles, IL 60714-4608 USA

Phone: 847-600-2000
Fax: 847-600-6446
Email: international@shure.com